

LED Surface Panel

2X2 & 2X4

Features

- Sustainable illumination
- Flat Panel with Included Surface mount kit
- 2x2 & 2x4 configuration
- UL listed, DLC certified
- 0-10v Dimmable

Specifications

- 100-277v standard.
- Long life LEDs coupled with 100-277v high efficiency drivers provide quality illumination. Rated to deliver L80 performance > 50,000 hours. CRI >80
- CCT 4000k, 5000k
- White plastic diffuser distributes even light throughout.
- Designed for surface mount applications.
- Operating temperature -4° to +104° F
- Led flat panel converts to surface mount with included kit.

Application

- Schools
- Retail Stores
- Offices
- Hospitals
- Nursing Homes



Accessories

- Emergency Battery Pack

Catalog Number	Type

LED Surface Panel

2X2 & 2X4

Dimensions and specifications are subject to change. Consult factory for verification.

Dimensions

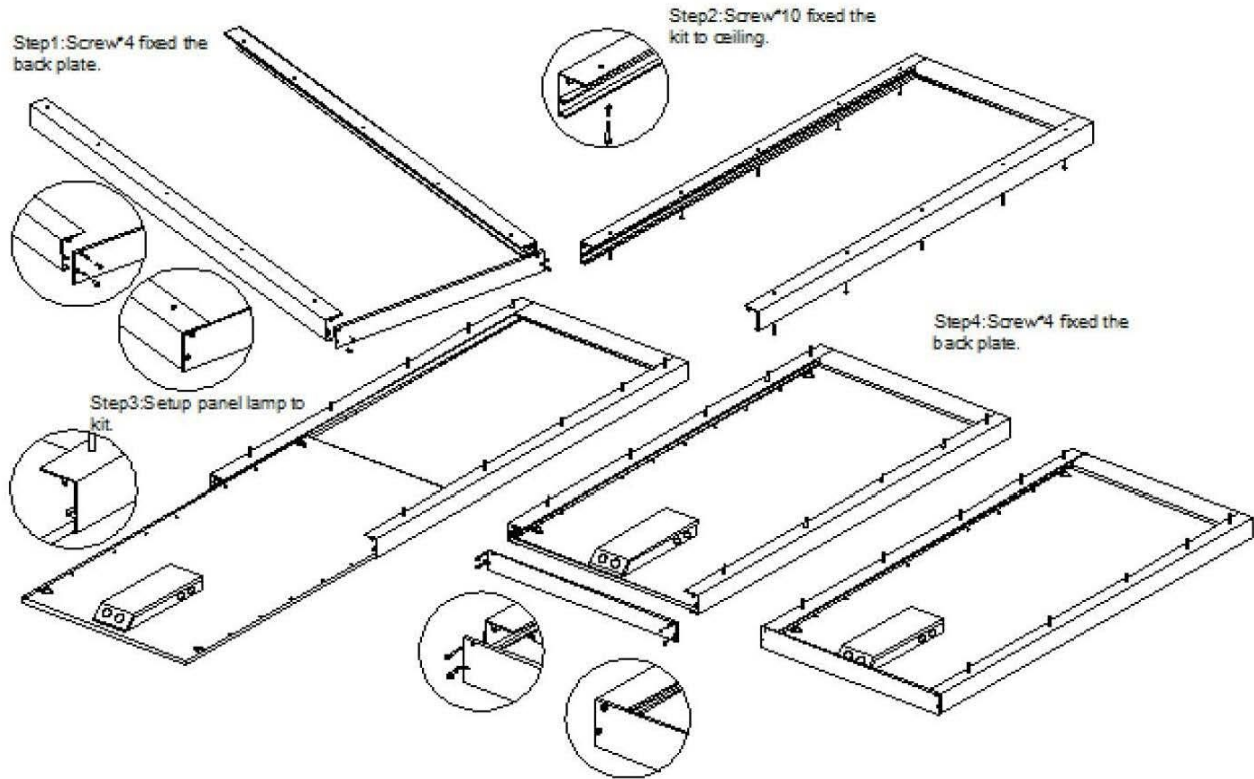

Size	Luminous Flux	Watts
2'x2' x2.15" H	4200 lm	40w
2'x4' x2.15" H	5400 lm	50w

Ordering Information

Example: LED-SU-PL-24-50W-4K

